



## CW-150 - CHECKWEIGHER FOR TABLETS & CAPSULES

New and innovative in-line solution designed to ensure the quality of each individual tablet or capsule up to OEB3 level products.

The CW-150 measures individual mass from each single tablet or capsule up to a speed of 150.000 objects per hour and rejects all non-compliant products.

The ideal tool for in-line Quality Inspection and RTD (Real Time Decision). It can also be used off-line for batch recovery inspection.

### KEY BENEFITS

- 100% weight control of tablets & capsules
- Accuracy +/- 1mg (3 Sigma)
- Upgradable to 100% Content Uniformity Weight + %APIs
- Up to 150.000 objects/H
- Single line system - less maintenance & calibration time
- Fast & Easy change-over
- ≤ OEB3

MASS



≤ OEB3

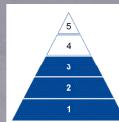

# 3D MICROWAVE RESONATOR FOR: WEIGHT MEASUREMENT

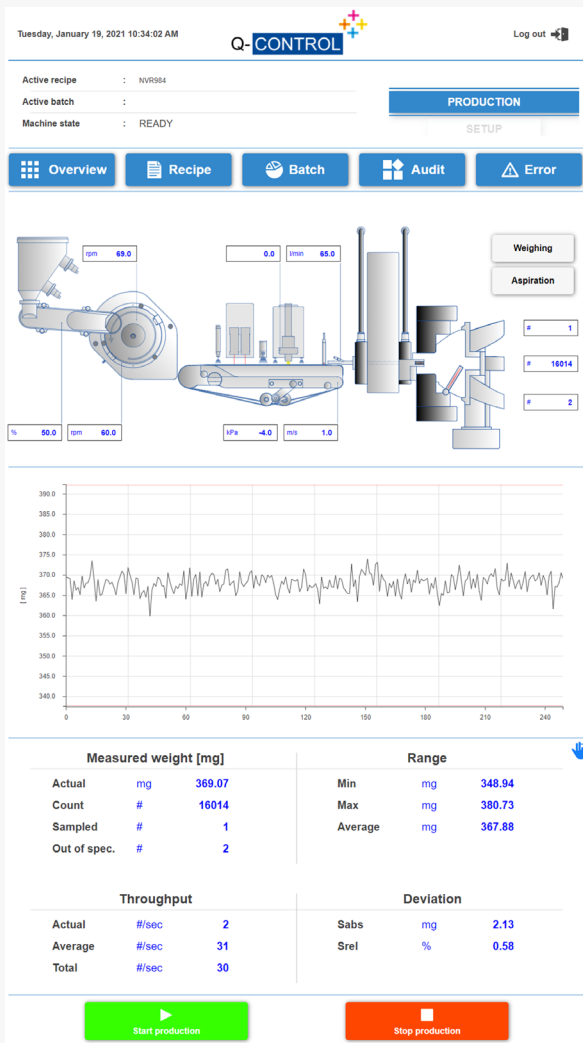

Each product is inspected by the 3D microwave resonator allowing to measure individual mass to the accuracy of +/- 1mg (3 sigma).

Various extensive repeatability tests campaigns and industrial case studies have shown that the measurements are within the predicted errors boundaries.

The CW-150 is geared to provide an accurate mass and to remove 100% non-compliant products from the the product stream, allowing RTD (Real Time Decision).

The CW-150 use simple calibration protocol for calibrating & validating the 3D microwave resonator based on a multiple linear regression principle. Samples are sent to a very accurate weigh cell located in a closed stable chambre to serve as reference method for the indirect mass predictions.

This isolated chambre can also be equipped with a special-ly highly precise 4-P tester to test physical attributes of your products based on conventional sampling methods (mass, thickness, hardness, and length/diameter).

3D microwave resonator



The unit has been developed with an utmost care to the mechanical design allowing fast and unexpansive format changes.

Data are processed and analysed by high speed processors and stored in a userfriendly “step by step” CFR21 acquisition software.

Data can easily be exported to an up-stream machine or software through OPC UA (e.g. connection to a upstream or downstream process equipment). A special care has been taken to simplify the equipment to allow use in a production environment.

Designed to comply with common guidelines (i. e. the European Union's CE Guidelines, UL...) they are supplied with a manual, safety instructions and wiring diagram

### 100% CAPSULES WEIGHING



Automatic Calibration

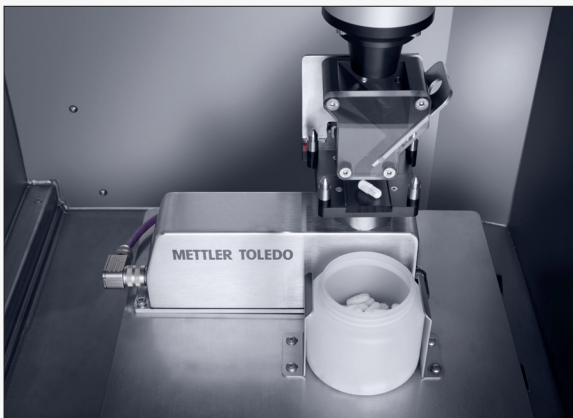

### 100% TABLETS WEIGHING



Automatic Calibration

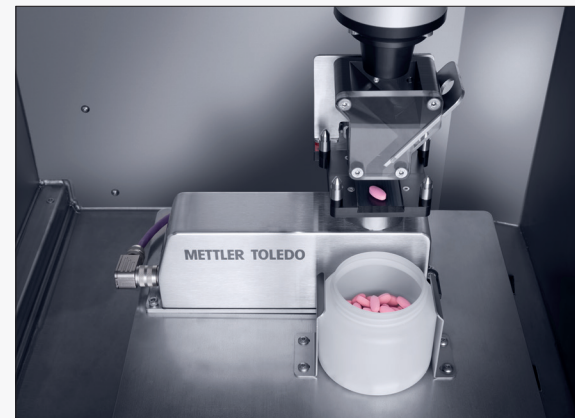

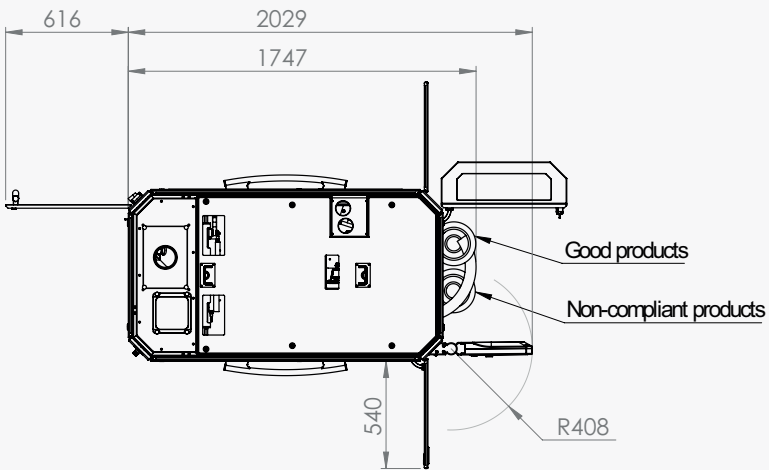
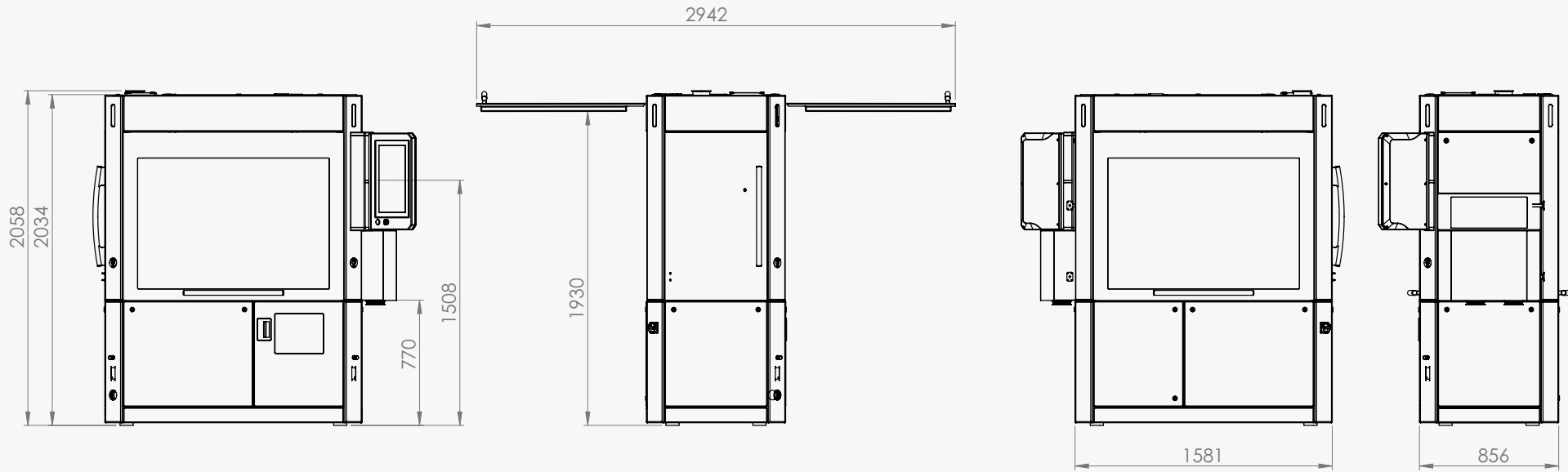

## TECHNICAL SPECIFICATIONS

Maximum throughput (size or shape dependent)	150.000 objects/h
Minimum product width (tablets)	4 mm
Maximum product width (tablets)	24 mm
Maximum product height (tablets)	9 mm
Size range (capsules) (hard gelatine)	000 to 5
Weighing range	20mg to 2000 mg
3D mass measurement accuracy	+/- 1mg (3 Sigma)
Air extraction	Integrated with Hepa filter H13
Requested compressed air	500L/min - min. 6 bar
Noise level	≤70 dB (A)
Power supply	380V 3ph + N + PE
Frequency	50 Hz / 60 Hz
Polymer contact parts	FDA approved